

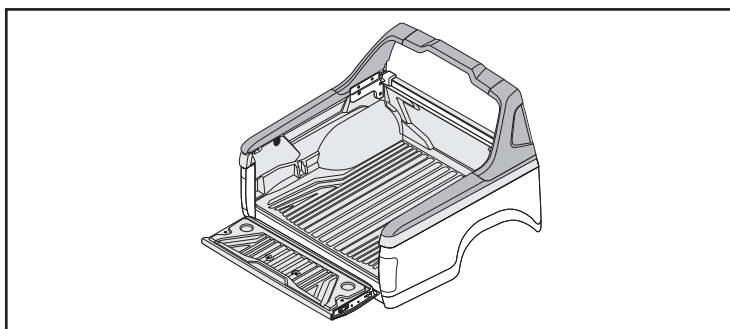

# STYLISH BAR INSTALLATION INSTRUCTIONS



## Caution for installation

Read this mounting manual carefully, before your start the installation.

1. Area where to install product should be clean.
2. During installation, person who installed should take off any ornaments.

Product name : MAX STYLISH BAR for LINER O/R  
 Model name : ISUZU RT-50 DBC 2012  
 Inst. number : L23-0026

## Component parts

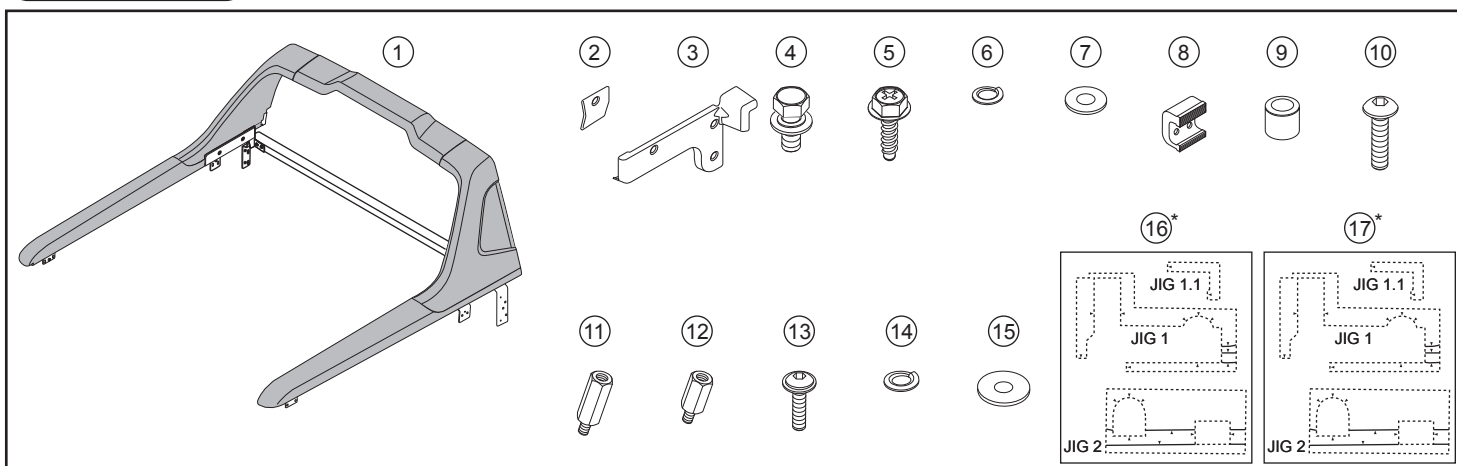

No.	Part name	Q'ty
1.	Sport bar set	1 set
2.	Cover side sport bar 03 OR	1 set
3.	Cover side sport bar 02 LH/RH OR	1 set
4.	Bolt set M8 (white)	4 pcs.
5.	Flang bolt M8 L25 (black)	4 pcs.
6.	Spring washer M8 OD14.1 (white)	4 pcs.
7.	Plain washer M8 OD18 (white)	4 pcs.
8.	Clamp lock L60	2 pcs.
9.	Collar M8 L15 (black)	4 pcs.
10.	Round socket bolt M8 L40 (white)	4 pcs.
11.	Super nut M6 L35 (black)	4 pcs.
12.	Super nut M6 L30 (black)	4 pcs.
13.	Truss head screw M6 L15 (black)	8 Pcs.
14.	Spring washer M8 OD14.5 (black)	4 pcs.
15.	Plain washer M8 OD23 (black)	4 pcs.
16.*	Paper jig set for logo MAX liner	1 Set
17.*	Paper jig set for logo FALCON liner	1 Set

## Tools used

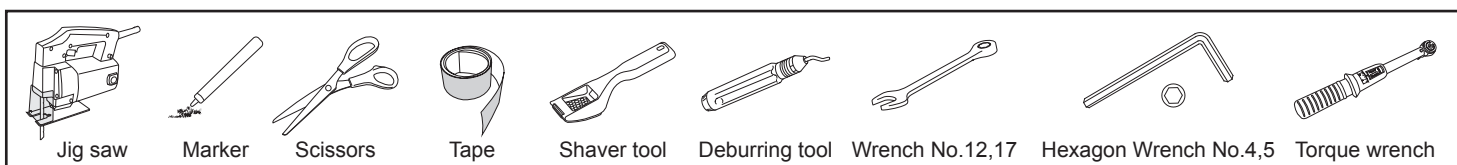

## Instruction procedure

1 RH/LH is symmetry. (The figure show LH)

1.1

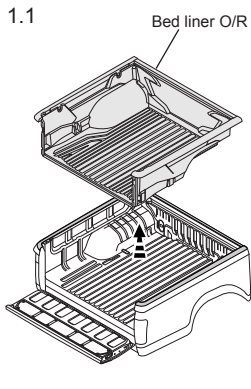

Bed liner O/R

JIG 1.1

JIG 1

JIG 2

Paper jig (16)/(17)\*

Jig 1

Jig1.1

1.2

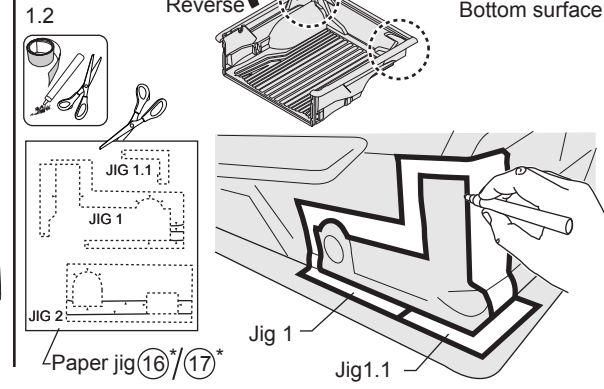

Reverse

Bottom surface

1.3

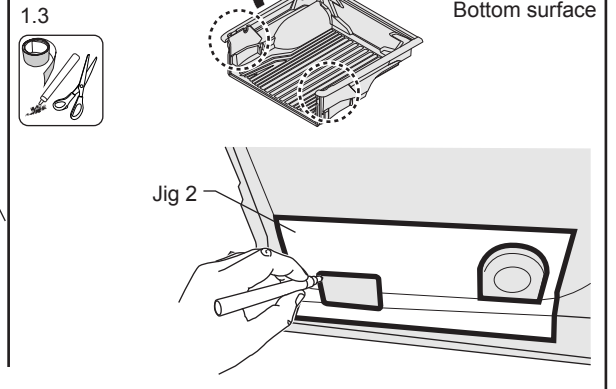

Reverse

Bottom surface

Jig 2

2

2.1

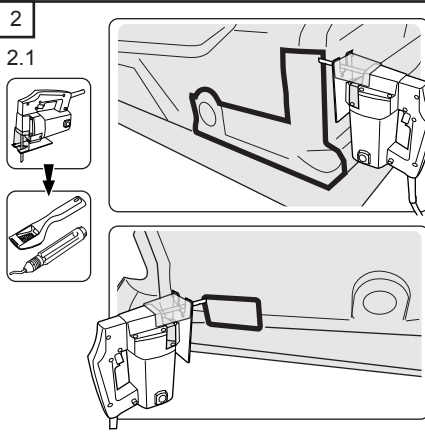

2.2

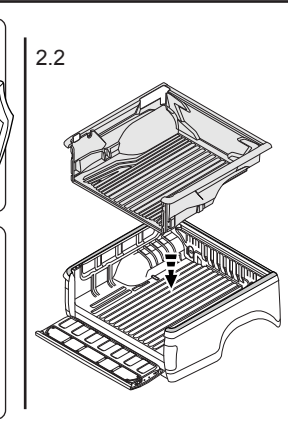

3

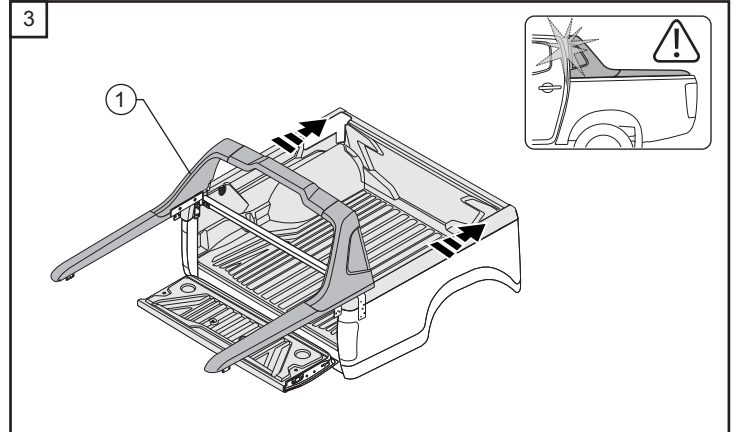

4 RH/LH is symmetry. (The figure show LH)

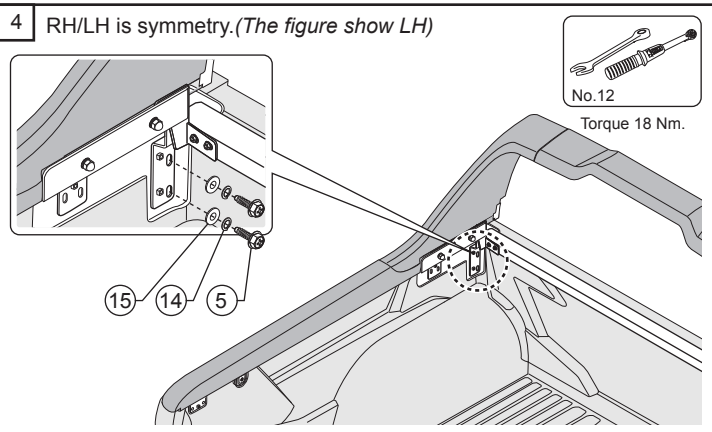

No.12

Torque 18 Nm.

15

14

5

5 RH/LH is symmetry. (The figure show LH)

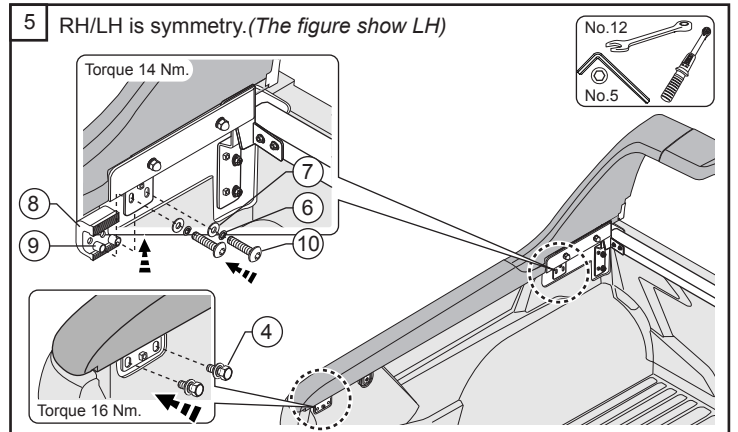

Torque 14 Nm.

No.12

No.5

7

6

8

9

10

Torque 16 Nm.

4

6 RH/LH is symmetry. (The figure show LH)

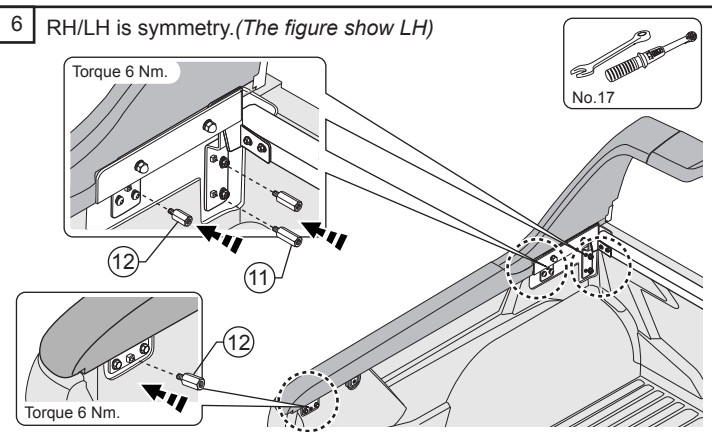

Torque 6 Nm.

No.17

12

11

Torque 6 Nm.

7 RH/LH is symmetry. (The figure show LH)

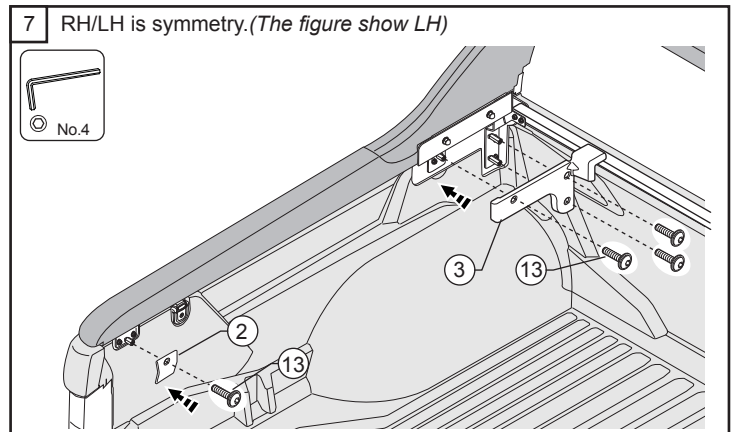

No.4

3

13

2

13

7

6

5

4

3

2

1

A

B

C

D

E

B

A

PAPER JIG TRIM LINE " O/R "
LOGO MAX , LOGO FALCON
JIG 1 - RH

ALIGN HERE

A

ALIGN HERE

JIG 1.1 - RH

B

JIG 2 - RH

ALIGN HERE

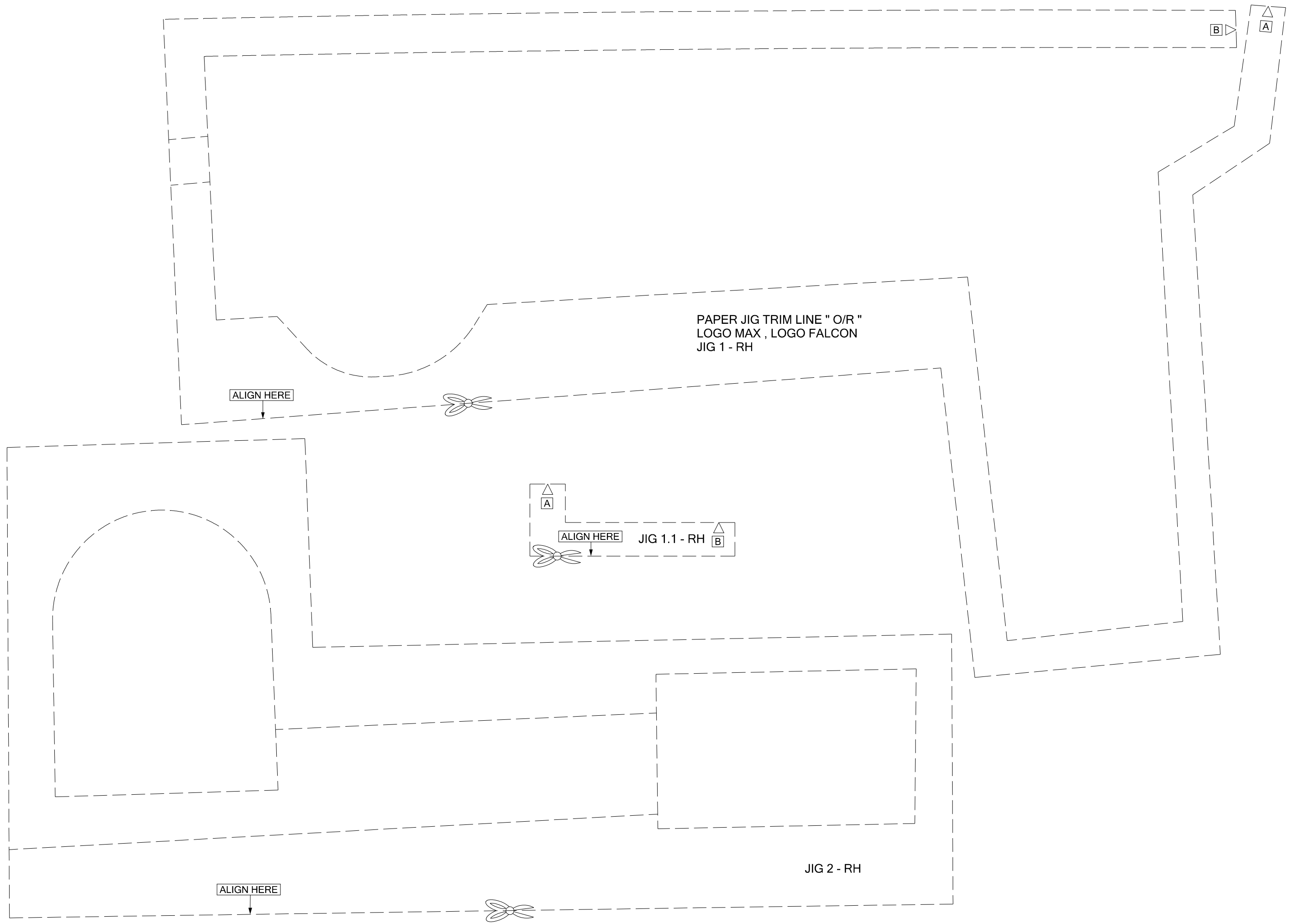
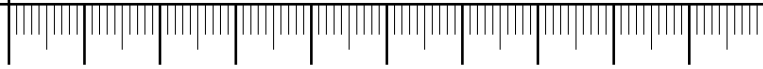
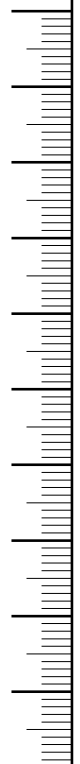

7

6

5

4

3

2

1

A

B

C

D

E

A B

PAPER JIG TRIM LINE " O/R "
LOGO MAX , LOGO FALCON
JIG 1 - LH

ALIGN HERE

JIG 1.1 - LH
ALIGN HERE

JIG 2 - LH

ALIGN HERE

